

ASSEMBLY INSTRUCTION

ITEM#:161834CT 212946CT

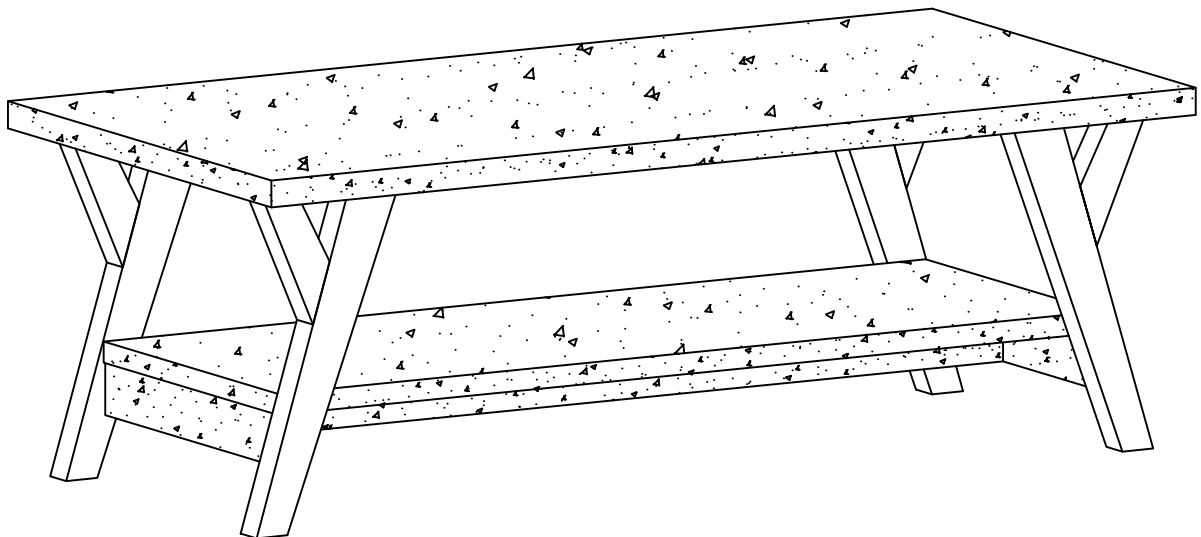

ASSEMBLY INSTRUCTION

PLEASE READ BEFORE ASSEMBLING!

Tip #1: Make sure you've taken all the pieces and hardware out of its packaging before discarding the box.

Tip #2: Using page 2 and/or page 3 of instruction manual make sure all pieces and hardware are accounted for.

ITEM#:161834CT 212946CT

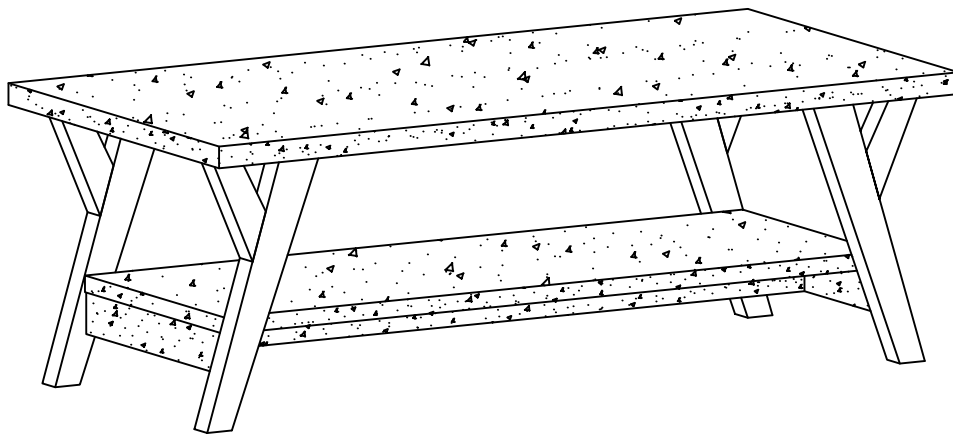

PARTS IDENTIFICATION



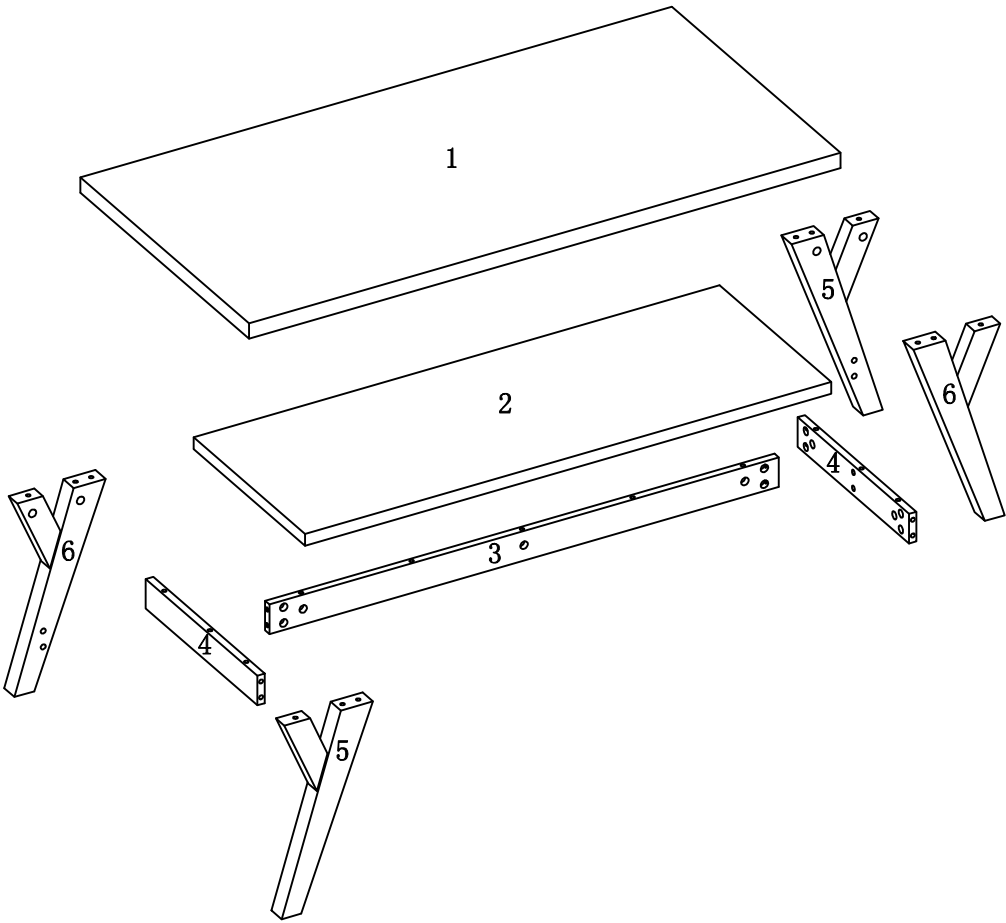



ITEM#:161834CT 212946CT



- | | |
|-----|------|
| (1) | 1pc |
| (2) | 1pc |
| (3) | 1pc |
| (4) | 1pc |
| (5) | 1pc |
| (6) | 2pcs |
| (7) | 2pcs |



HARDWARE IDENTIFICATION

ITEM#:212946CT

A		L29	21PCS
B		Φ 15	21PCS
C		Φ 8x25	16PCS
D		Φ 22 (DGY)	8PCS
E		Φ 16	4PCS
F		Glue: For securing please apply to wood dowel first before inserting into panel	1PC

HARDWARE IDENTIFICATION

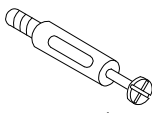
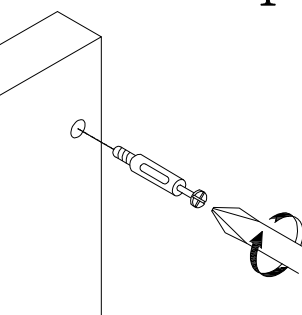
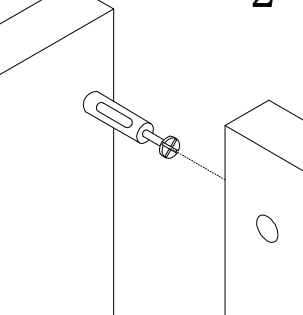
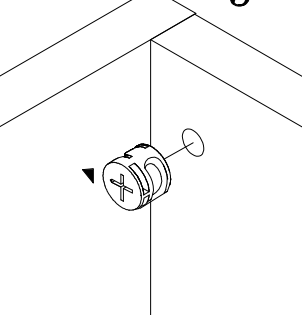
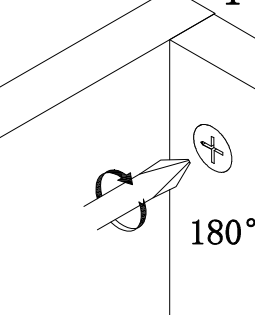
ITEM#:161834CT 212946CT

HOW TO	1	2	3	4
 Cam Bolt				
 Cam Lock	1. Screw Cam Bolt into panel.	2. Insert Cam Bolt into bolt hole of joining panel.	3. Insert Cam Lock. arrow facing bolt.	4. Gently turn Cam Lock clockwise to lock position.

STEP 1

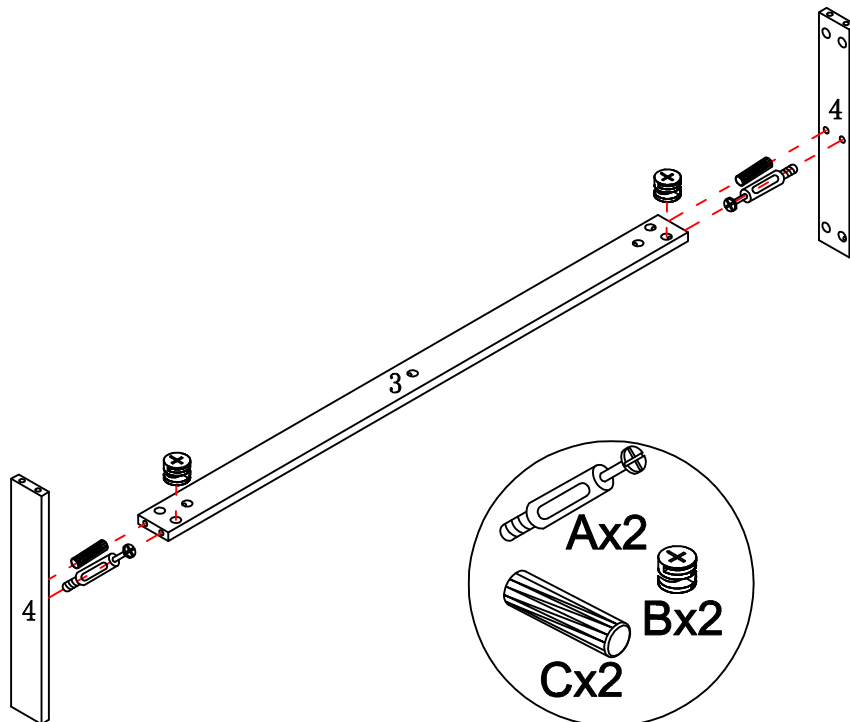

HARDWARE IDENTIFICATION

ITEM#:161834CT 212946CT

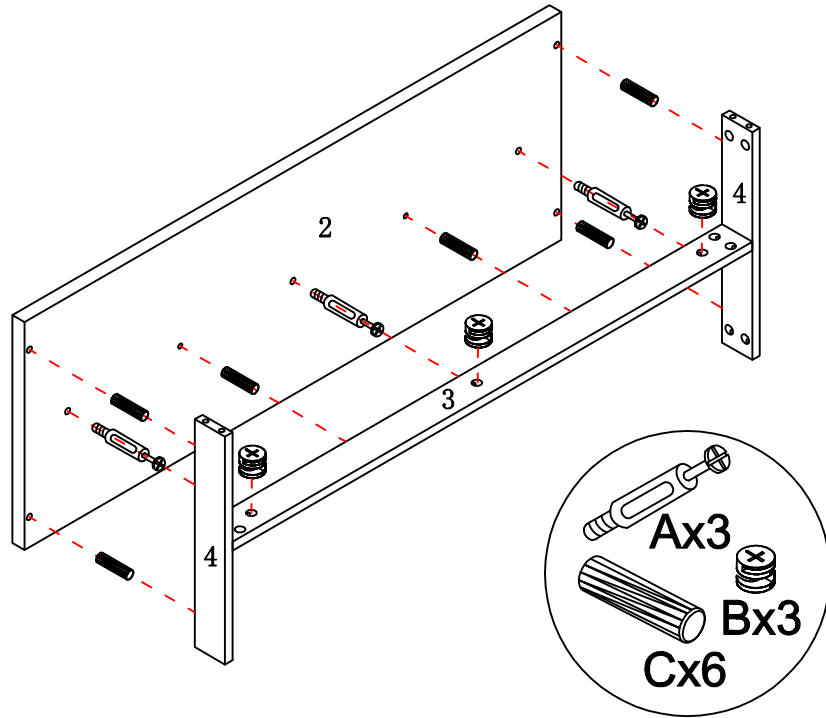

STEP2

STEP3

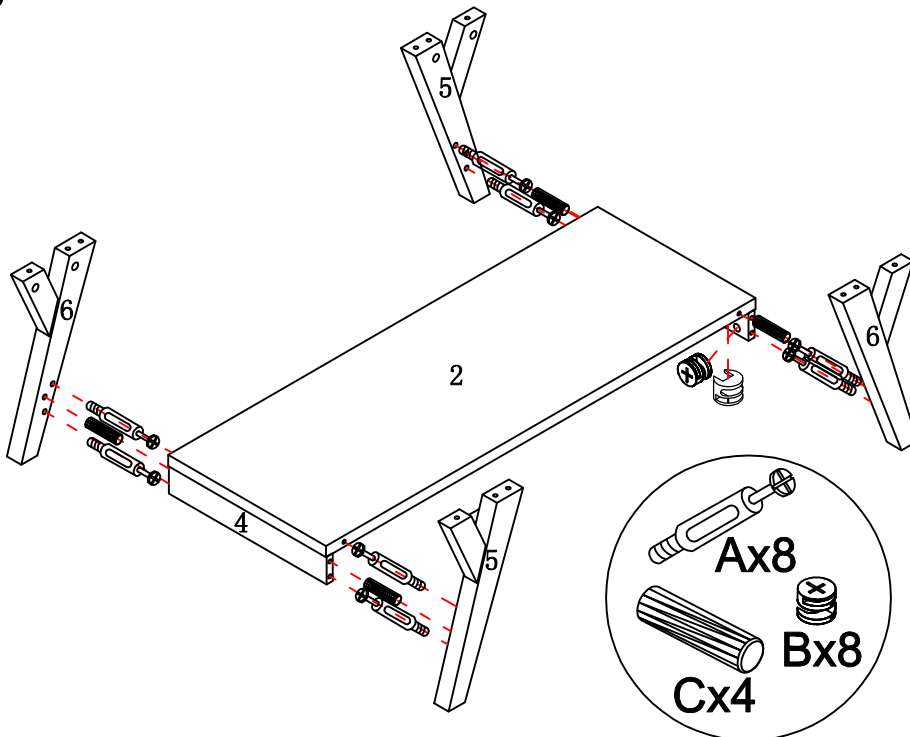

PAGE:5 OF 6

HARDWARE IDENTIFICATION

ITEM#:161834CT 212946CT

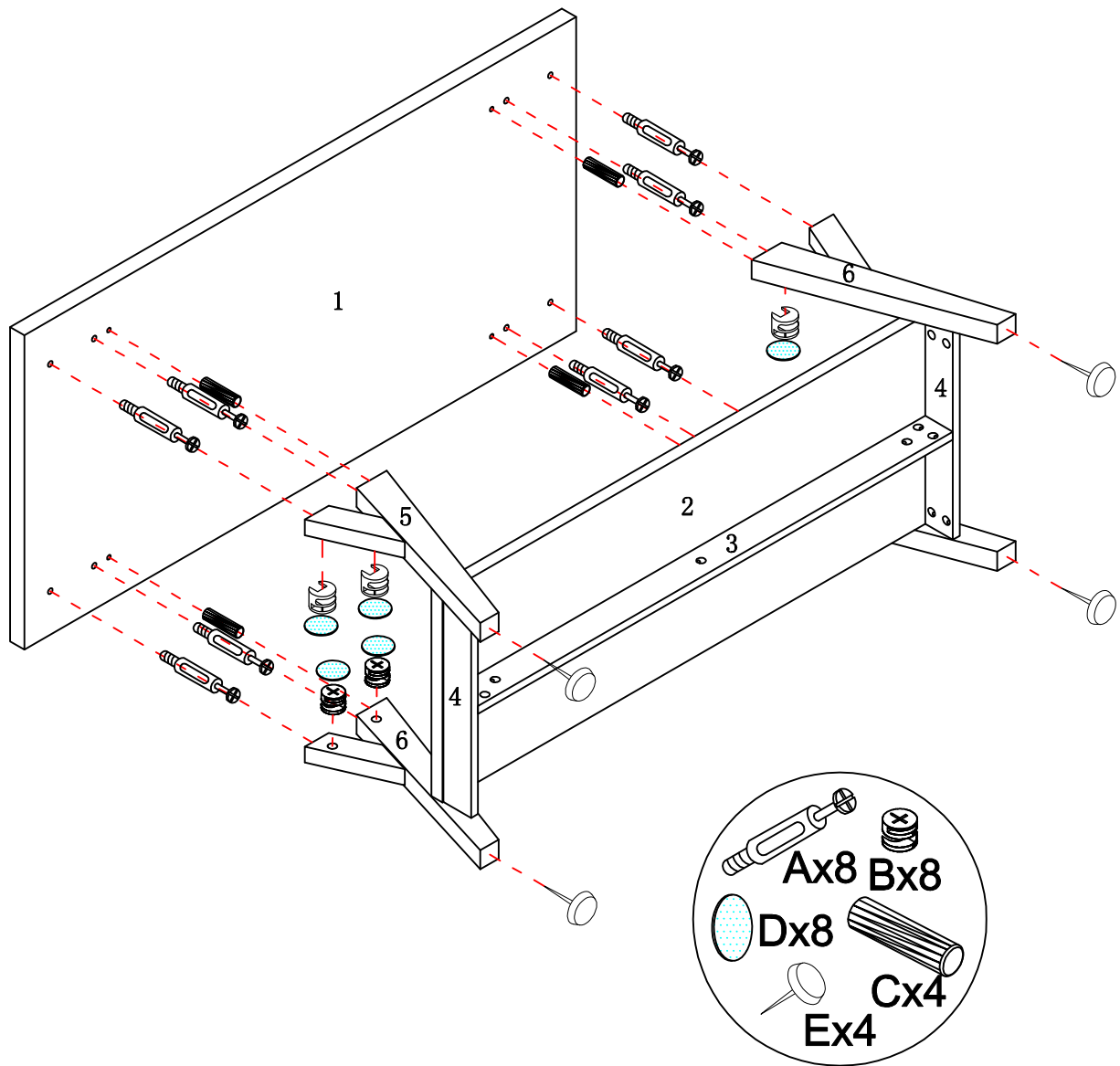

STEP4

