

# ASSEMBLY INSTRUCTION

---

ITEM#: 182330 182331

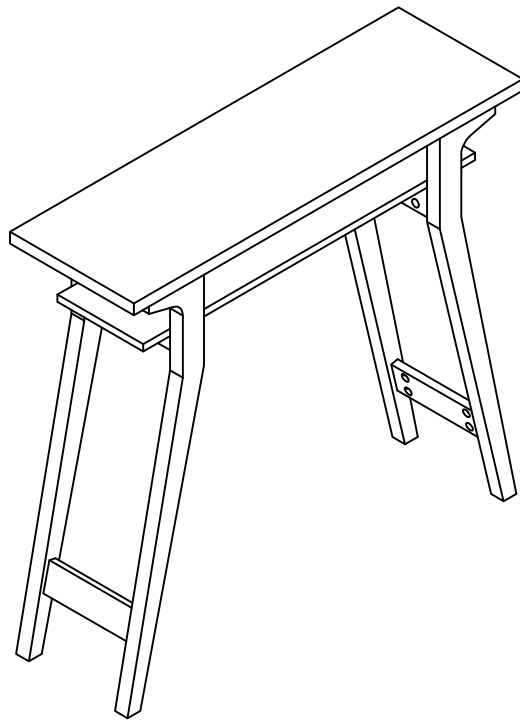

# ASSEMBLY I NSTRUCTION

---

## PLEASE READ BEFORE ASSEMBLING!

Tip #1: Make sure you've taken all the pieces and hardware out of its packaging before discarding the box. Assembly on top of flattened box/blanket is recommended.

Tip #2: Using page 2 and/or page 3 of instruction manual make sure all pieces and hardware are accounted for.

Tip #3: Note position of all holes on each panel during assembly .

ITEM#: 182330 182331

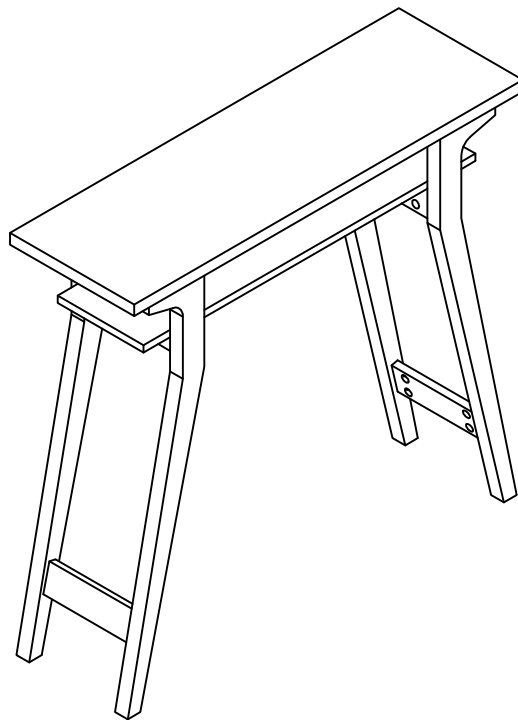

# PARTS IDENTIFICATION

ITEM#: 182330 182331

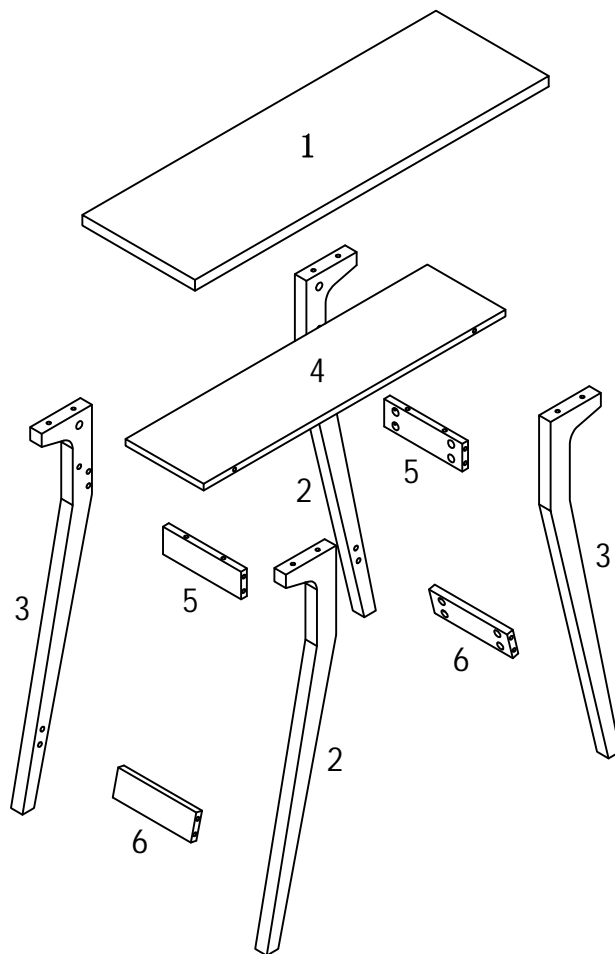

- (1) 1pc
- (2) 2pcs
- (3) 2pcs
- (4) 1pc
- (5) 2pcs
- (6) 2pcs

# HARDWARE IDENTIFICATION

ITEM#: 182330 182331

A  
B  
C  
D  
E  
F  
G  
H  
I  
J  
K



L29

24pcs



Ø15

24pcs

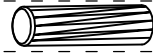

Ø8x25

8pcs

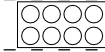

Ø22

24pcs



Ø16

4pcs



197×5×1

1pc



Ø4x25

1pc

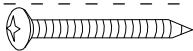

Ø5x40

1pc



Ø8 x 40

1pc



12×12×1

2pcs

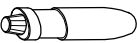



Glue: For securing please apply to wood dowel first before inserting into panel

1pc

# ASSEMBLY INSTRUCTION

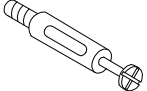
ITEM#: 182330 182331

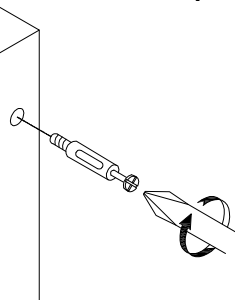
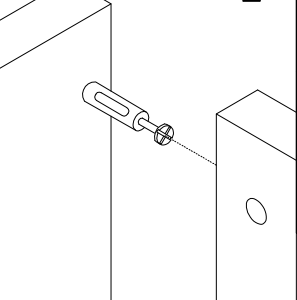
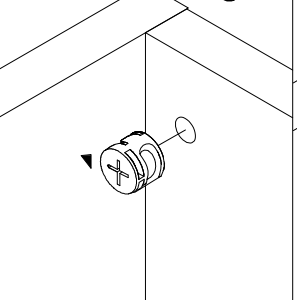
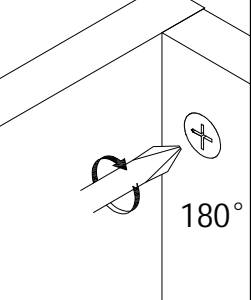
HOW TO	1	2	3	4
 Cam Bolt   Cam Lock				 180°
	1. Screw Cam Bolt into panel.	2. Insert Cam Bolt into bolt hole of joining panel.	3. Insert Cam Lock. arrow facing bolt.	4. Gently turn Cam Lock clockwise to lock position.

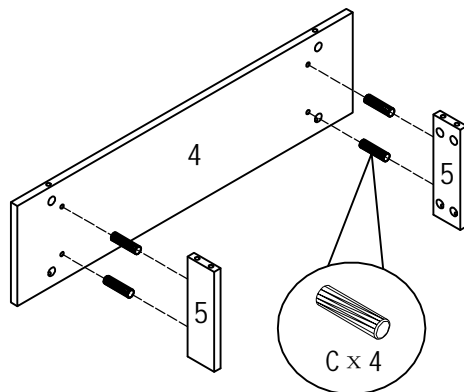

## STEP1

## STEP2

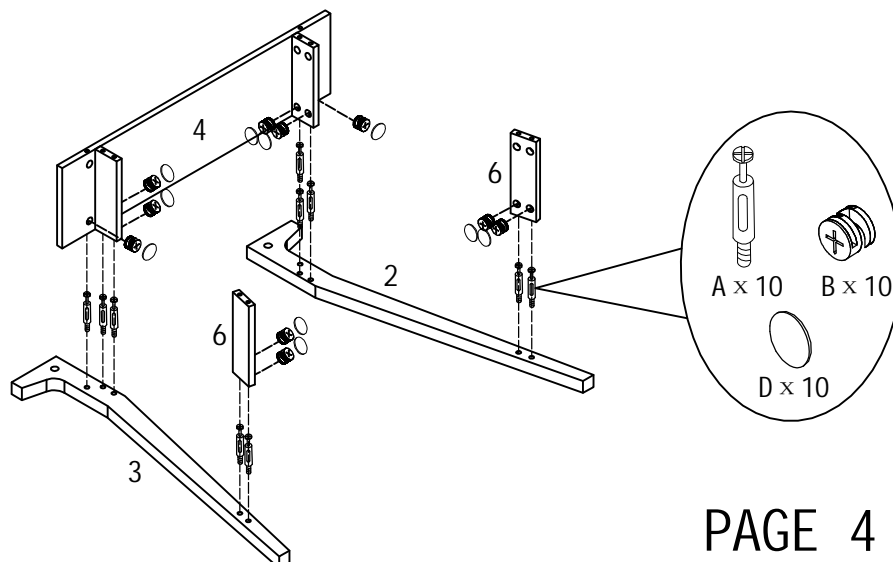

# ASSEMBLY INSTRUCTION

ITEM#: 182330 182331

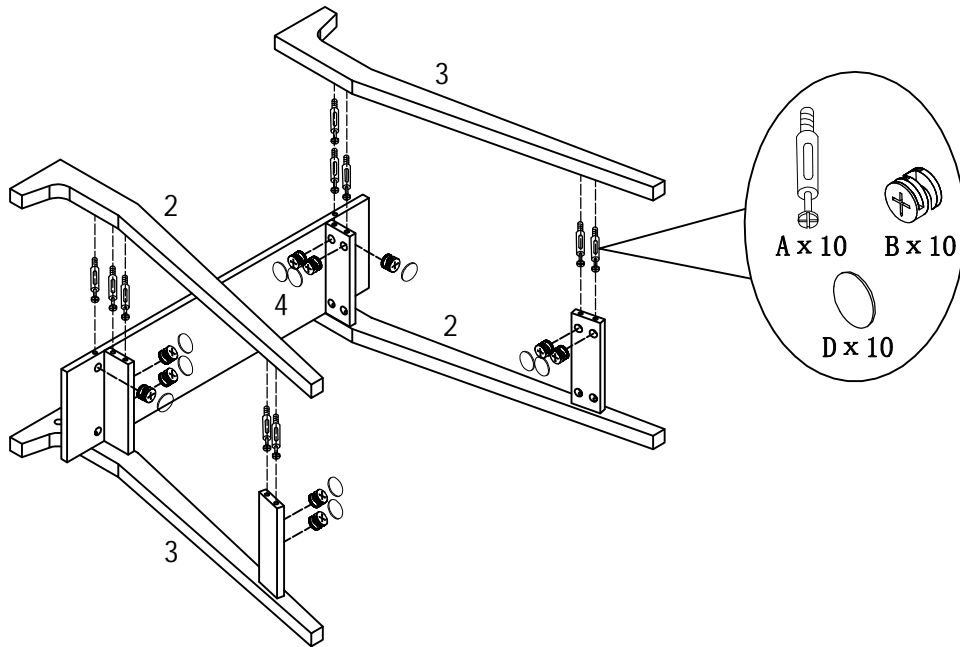

STEP3

STEP4

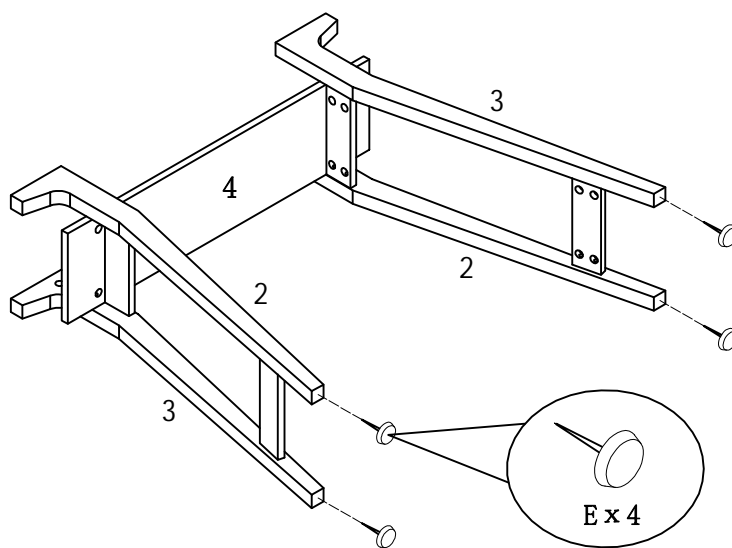

# ASSEMBLY INSTRUCTION

ITEM#: 182330 182331

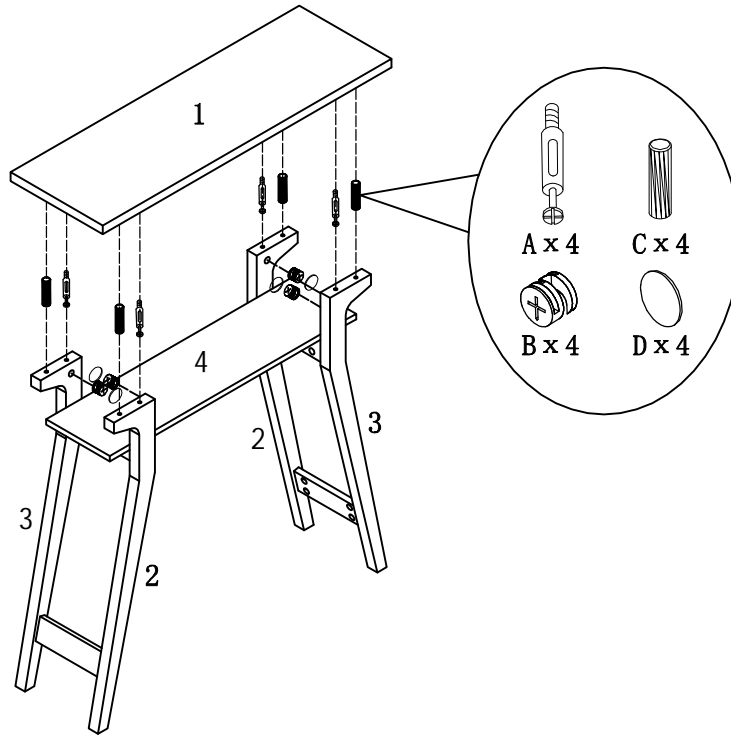

STEP5

STEP6

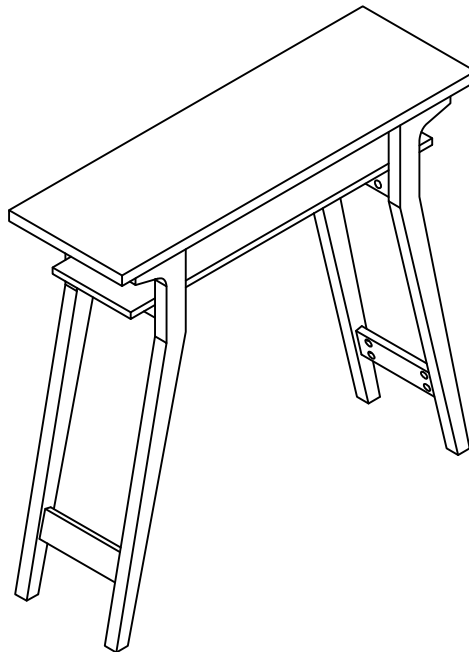

# ANTI-TIPPING STRAP INSTRUCTION

HARDWARE (INCLUDED):

TOOLS NEEDED ( NOT INCLUDED):

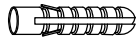

DRYWALL ANCHOR  $\phi 8 \times 40$  X 1PC

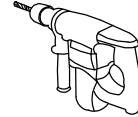

DRILL & DRILL BIT

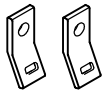

METAL BRACKETS  $12 \times 12 \times 1$  X 2PCS



LIGHT HAMMER

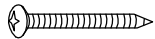

DRYWALL SCREW  $\phi 5 \times 40$  X 1PC



STRAP  $197 \times 5 \times 1$  X 1PC



FLATHEAD SCREW  $\phi 4 \times 25$  X 1PC

Note: Hardware included only compatible with standard drywalls.

## STEP 1

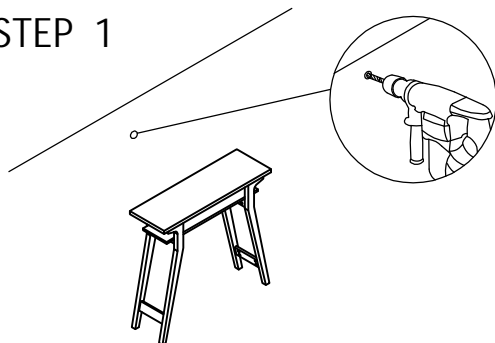

1. Find spot on wall 1" below top of item.
2. Using a drill bit slightly thinner than anchor, drill hole into drywall.

## STEP 2

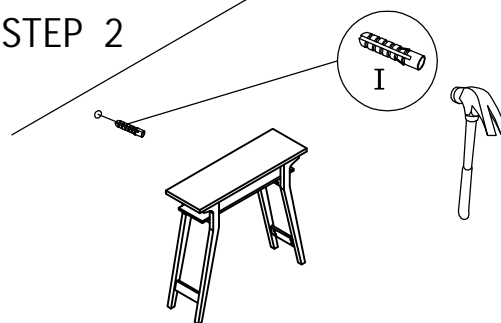

1. Use a light hammer to tap anchor into hole.
2. Anchor should fit snugly. If hole is too small, drill again to increase hole size. Do not force anchor into wall.

## STEP 3

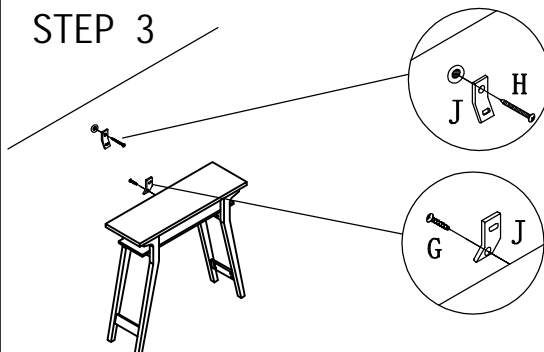

1. Insert drywall screw into metal bracket and into drywall anchor.
2. Insert flathead screw into second metal bracket and into back of item, along top edge.

## STEP 4

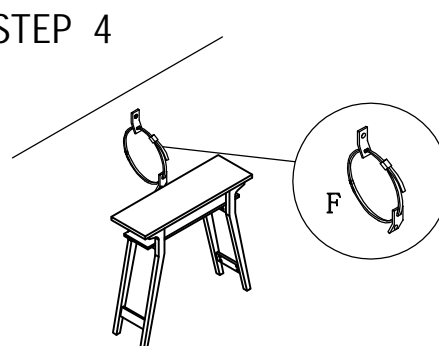

1. Insert strap thru bracket attached to wall, then thru bracket on item, and into head of strap.
  2. pull lightly til strap stops.
- Assembly is complete.